

CONTENTS

Residential Insurance Policy

Effective September 2021



Mike Pero

Mortgages • Insurance • Finance

Index

Welcome to your Mike Pero Contents Residential Policy – insurance for your contents	3
Cover Option – Premier	5
Cover Option – Restricted	12
Exclusions – things we don't cover	17
Making a claim	23
How we'll settle your claim under Cover Option – Premier	25
How we'll settle your claim under Cover Option – Restricted	29
What your responsibilities are	32
Policy conditions and other important information	34
Definitions	37

The online version of this document is interactive

Click a section on the index page, or any page number in this document, to go straight there.
To search for a keyword, type Ctrl + F on a PC or Command + F on a Mac.

Mike Pero insurance refers to the insurance policy, which is arranged by Aon New Zealand as the broker with Vero Insurance New Zealand Limited as the insurer.

Welcome to your Mike Pero Contents Residential Policy – insurance for your contents

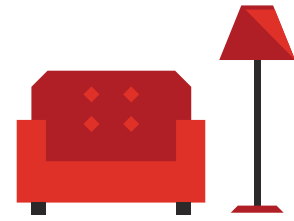

In this policy wording, we set out what's covered and what's not covered under your policy, your responsibilities, and how we work together with you at claim time.

Who we mean by 'you'

When we say 'you' or 'your', we mean the insured person or people named on your *schedule*, and their partner, their parents and/or their children (including dependent children within their care) – if they permanently live at the *home* with you and aren't covered by any other contents insurance.

A partner is either a:

- marriage or de facto partner under the Property (Relationships) Act 1976
- civil union partner under the Civil Union Act 2004.

Who we mean by 'we'

When we say 'we', 'us', or 'our', we mean Vero Insurance New Zealand Limited.

The documents that make up your insurance policy

Your insurance policy is made up of three parts.

1. This policy wording. It explains what we do and don't cover, the responsibilities you have under the policy, and how to make a claim.
2. Your policy *schedule*. It gives details specific to you, including who and what is insured, when cover starts and ends, and the *premium* you've agreed to pay. The policy *schedule* also includes any special terms that might apply, which might also detail things that we do and don't cover.
3. The information in your proposal, application, or declaration.

Read your policy wording, so you know what we do and don't cover

We agree to give you insurance cover as outlined in this policy wording and your policy *schedule*, as long as your *premium* payment is up to date.

Read your insurance policy documents carefully, so you know what you are, and are not, covered for. Keep them together in a safe place.

Once you've read this policy wording, contact your insurance adviser or Aon New Zealand if you would like more information.

Headings in this policy wording are descriptive

The headings used in this policy wording are descriptive – they're to help you find information. They're not part of the terms and conditions, so you can't rely on them to interpret the policy's meaning.

Words in italics have specific meanings

When words are in *italics*, they have specific meanings that we've defined in the 'Definitions' section on page 37. When we use these words, we mean the definitions we give in the 'Definitions' section.

What we cover depends on your cover option

The cover we provide under this policy depends on the cover option on your *schedule*. You'll have either Cover Option – Premier or Cover Option – Restricted.

Your home and contents

Your home

The residential building at the insured address and includes structural improvements, fixtures, fittings and domestic outbuildings.

Your contents

Includes your furniture, furnishings, valuables, personal possessions and unfixed household goods.

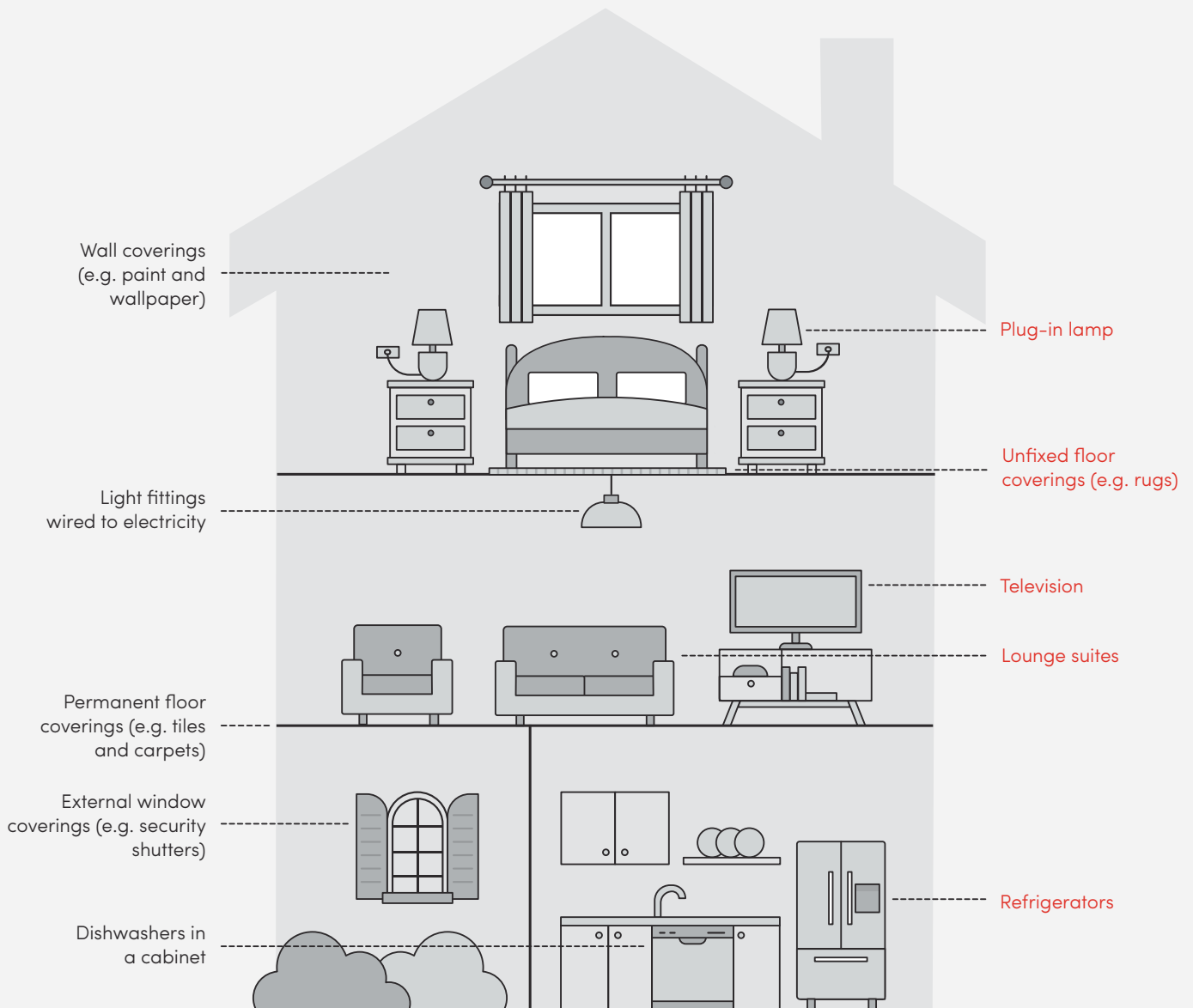

Cover Option – Premier

If your *schedule* shows you have Cover Option – Premier, we'll cover you for *loss* to your *contents* while they're:

- at your *home*
- temporarily moved from your *home* to use anywhere in New Zealand.

Any *loss* must happen during the *period of insurance*.

Your cover also includes the benefits below, if the circumstances they outline apply.

Your cover, including the benefits, is subject to the terms, limitations, exclusions, conditions, and cover limits that apply to this policy.

Benefits we include in your cover

This section explains in detail the benefits we provide, and what we'll pay for each.

- paid out of your *sum insured*

 paid in addition to your *sum insured*

BENEFIT	PAGE
<input type="checkbox"/> Alternative accommodation	6
<input checked="" type="checkbox"/> Authorities damage	6
<input checked="" type="checkbox"/> Boarding school	7
<input checked="" type="checkbox"/> Change of situation and transit cover	7
<input checked="" type="checkbox"/> Credit and debit cards	7
<input type="checkbox"/> Fatal injury	7
<input checked="" type="checkbox"/> Fusion of electric motors	7
<input checked="" type="checkbox"/> Gifts	7
<input checked="" type="checkbox"/> Gradual damage	8
<input checked="" type="checkbox"/> Home office or healthcare practice	8
<input checked="" type="checkbox"/> Misuse of mobile/smart phones	8
<input type="checkbox"/> Occupier's and personal liabilities	9
<input checked="" type="checkbox"/> Overseas travel	10
<input checked="" type="checkbox"/> Property used for trade, professional, or business use	10
<input checked="" type="checkbox"/> Specified items	10
<input checked="" type="checkbox"/> Stolen keys	10
<input checked="" type="checkbox"/> Storage of contents	11
<input checked="" type="checkbox"/> Tenant's improvements	11
<input checked="" type="checkbox"/> Tertiary accommodation	11
<input checked="" type="checkbox"/> Vehicle accessories within an employer's motor vehicle	11

Alternative accommodation — we'll pay for temporary accommodation if your home is uninhabitable

We'll cover your reasonably incurred extra costs for temporary accommodation if you can't live in your *home* because it is *uninhabitable* due to:

- *loss* this policy covers
- *loss* to the *home* that happens during the *period of insurance*, and the *contents* we're covering are in that *home*
- *loss* to the *home* that happens during the *period of insurance* that is covered entirely by the Earthquake Commission
- prevention of access to the *home* by government or local authorities which is initiated during the *period of insurance* because of possible or impending damage to an otherwise safe or sanitary *home*.

The temporary accommodation must be of a similar standard to your *home*.

This cover includes boarding your *domestic pets*, storing your *contents*, and moving your *contents* to and from storage or temporary accommodation.

If you own and live in the home

If you own and live in the *home* where your *contents* are insured, we'll pay up to 12 months of temporary accommodation or \$30,000, whichever is less.

If there has been a widespread *natural disaster*, we can choose to pay beyond the 12-month period.

If you are renting the home

If you rent the *home* where your *contents* are insured, we'll pay up to 1 month of temporary accommodation or \$5,000, whichever is less.

What we won't cover under this benefit

Under this benefit, we won't cover:

- any costs you would normally pay if your *home* was habitable, such as travel, consumables, phone charges, electricity, gas, or water supply services — or any increase in these costs associated with the temporary accommodation
- any costs of alternative premises for your home office or healthcare practice.

Situations where this benefit won't apply

This benefit will never apply if:

- your *home* is not *uninhabitable* (other than when authorities stop you from accessing your *home* as outlined above)
- we haven't agreed in writing that it's necessary for you to move out of your *home* while it's repaired or rebuilt
- the *loss* covered by the Earthquake Commission is only *loss* to land.

+ Any amount we pay under this benefit, we'll pay in addition to your *sum insured*.

Authorities damage — we'll cover damage caused to prevent other loss

We'll cover physical damage to your *contents* that government or local authorities cause to prevent *loss* that this policy covers.

The item limits in this policy still apply (see page 26).

✓ Any amount we pay under this benefit, we'll pay out of your *sum insured*.

Boarding school — we'll cover your children's contents while they're at boarding school

We'll cover your children's *contents* if your children are temporarily living away from home at a boarding school.

The item limits in this policy still apply (see page 26).

- ✓ Any amount we pay under this benefit, we'll pay out of your *sum insured*.

Change of situation and transit cover — we'll cover your contents at your old and new addresses when you move

When you move house, we'll cover your *contents* at both your old and new address for up to 30 days, as long as you tell us about the new address within the 30 days.

We'll stop covering the *contents* at the previous address 30 days after the *contents* are first removed, unless we've agreed in writing, before any *loss*, to continue providing cover.

While your *contents* are being moved between your old and new *home*, we'll cover them for *accidental loss* or damage arising from fire or theft from a locked vehicle. We'll also cover your *contents* if the vehicle being used to move them overturns or is in a collision. The most we'll pay for *contents* lost or damaged in transit is \$10,000 for each event. The item limits in this policy still apply (see page 26).

- ✓ Any amount we pay under this benefit, we'll pay out of your *sum insured*.

Credit and debit cards — we'll reimburse unauthorised use

If someone uses your lost or stolen credit or debit card, we'll reimburse you for your financial loss. We'll pay up to \$1,000 for any one event.

We'll pay if all the following apply.

- You complied with the conditions the card was issued under.
- You told the police and your card issuer within 24 hours of discovering the financial loss.
- The financial loss can't be recovered from anywhere else.

- ✓ Any amount we pay under this benefit, we'll pay out of your *sum insured*.

Fatal injury — we'll make an additional payment for fatal injury from fire or burglary

We'll pay \$10,000 to your legal representative or estate if you are injured at *home* in a fire or burglary and you die of the injury within 3 months.

- + Any amount we pay under this benefit, we'll pay in addition to your *sum insured*.

Fusion of electric motors — we'll cover fusion or burnout

We'll pay to replace electric motors if they burn out or fuse.

We'll also pay for an exchange sealed compressor for motors in a sealed refrigeration or air-conditioning compression unit and for re-gassing the unit.

- ✓ Any amount we pay under this benefit, we'll pay out of your *sum insured*.

Gifts — we'll cover special occasion gifts

We'll cover gifts for weddings, Christmas, and other special occasions if they are in your *home* temporarily and belong to someone other than you.

- ✓ Any amount we pay under this benefit, we'll pay out of your *sum insured*.

Gradual damage — we'll cover gradual damage caused by leaking water pipes

We'll pay up to \$3,000 for any one event for gradual physical damage to your *contents* resulting from water leaking or overflowing from any internal water system.

We'll only pay if both of the following apply.

- The damage must have first started after you moved into your *home*.
- The leak or overflow causing the *loss* wasn't visible, noticeable, or obvious.

An internal water system is either of the following:

- any water pipe, waste disposal pipe, or water storage tank which is permanently connected and contained within the walls, cupboards, floors, ceiling, or roof of the *home*.
- any pipe hidden from view that is connected to a water cylinder, refrigerator, water purifier, washing machine, dishwasher, or similar household item that is designed to both receive and release water. An internal water system does not include the appliance itself.

- ✓ Any amount we pay under this benefit, we'll pay out of your *sum insured*.

Home office or healthcare practice — we'll cover your equipment

We'll pay up to \$15,000 for *loss* to home office and healthcare equipment if all the following apply.

- You own the equipment.
- You use it for business purposes.
- It's in your *home*.

What we mean by home office equipment

Home office equipment includes:

- office furniture
- computer and peripheral equipment
- fax machines
- photocopiers
- stationery.

What we mean by healthcare equipment

Healthcare equipment includes any:

- home office equipment as listed above
- equipment appropriate to the practice of a legally qualified health practitioner, as defined by the Health Practitioners Competence Assurance Act 2003.

- ✓ Any amount we pay under this benefit, we'll pay out of your *sum insured*.

Misuse of mobile/smart phones — we'll reimburse unauthorised use

If your mobile phone is lost or stolen, we'll pay up to \$500 for any unauthorised use your network service provider bills you for.

You must tell your network service provider as soon as you discover the *loss* or theft of your phone – we'll only pay for the first 24 hours of unauthorised use.

- ✓ Any amount we pay under this benefit, we'll pay out of your *sum insured*.

Occupier's and personal liabilities — we'll cover your legal liability if you cause loss, damage, or injury

We'll cover you for your legal liability to pay *damages* or *reparation* for *loss* to someone else's property, or *accidental bodily injury*, that happens during the *period of insurance*.

The liability must arise from an event that happens in New Zealand.

What you must do to be covered for liability for reparation

To be covered for liability for *reparation*, you must do both of the following.

- Tell us immediately if you're charged with any offence which resulted in *bodily injury* to another person or *loss* to someone else's property.
- Obtain our written approval before any offer of *reparation* is made.

Extended liability

As long as the above requirements for cover are met, we'll also extend cover for liability for *damages* and liability for *reparation* to include:

- your children who are covered by the 'Boarding school' benefit (page 7) and 'Tertiary accommodation' benefit (page 11)
- your involvement in paid part-time baby-sitting
- using ride-on mowers, other domestic garden appliances, electric wheelchairs, and electric mobility aids
- using any canoe, kayak, surfboard, surf ski, kite surfer, paddle board, windsurfer, or boat. We won't cover liability arising from the use of any boat that has a *market value* of more than \$3,000
- non-competitively using any of the following radio-controlled scale-models.
 - Aircraft
 - Watercraft
 - Motor vehicle.

What we won't pay under Occupier's and personal liabilities

We won't pay for any punitive or exemplary *damages* awarded against you.

We won't pay for legal liability:

- for *loss* to property that you own or that's under your custody and control, except for your *home* when you live in it as a *tenant*
- arising from:
 - your ownership of any building or land, including your *home*
 - any business, profession, or employment
 - your ownership, possession or use of any mechanically propelled vehicle, trailer, aircraft (including *drones*), or any boat where the *market value* of the boat is more than \$3,000
 - the ownership or possession of any animals, other than *domestic pets*.
- assumed by agreement, except if you would have been liable anyway
- where any exclusion in the 'Exclusions — things we don't cover' section applies (see pages 17 to 22).

Limits on what we'll pay for Occupier's and personal liabilities

For any one event, we'll pay:

- for *loss* to someone else's property, up to \$2,000,000
- for *bodily injury*, up to \$1,000,000.

The most we'll pay for all legal liabilities for *damages* and *reparation* is a combined total of \$2,000,000 during any *period of insurance*.

If you have other insurance with us that may cover liability for the same event, we'll still only pay up to the limits above.

We also pay legal defence costs if you are legally liable to pay damages

Where you're legally liable to pay *damages*, and we've given you our agreement in writing beforehand, we'll also pay your legal defence costs and expenses incurred. We won't pay legal defence costs and expenses in relation to an offence, or when you're legally liable to pay *reparation*.

- + Any amount we pay under this benefit, we'll pay in addition to your *sum insured*.

Overseas travel — we'll cover some contents you take to Australia or the Pacific Islands

While you're travelling to, from and within Australia or the Pacific Islands for personal or business reasons during the *period of insurance*, we'll cover your:

- clothing and personal effects
- suitcases and bags
- jewellery and watches
- cameras.

We'll pay this benefit if all the following apply.

- Your entire trip is no longer than 30 days in total.
- A travel insurance policy doesn't cover your *contents*.
- You report *loss* by theft or burglary to local police within 24 hours of discovering it.

We'll pay up to \$5,000 in total during any one *period of insurance*. The item limits in this policy still apply (see page 26).

- ✓ Any amount we pay under this benefit, we'll pay out of your *sum insured*.

Property used for trade, professional, or business use — we'll cover business tools

We'll cover your tools and other items you use for trade, professional, or business purposes.

This benefit doesn't cover products, or any stock of goods or materials, whether they're raw or finished.

We'll pay up to \$2,000 in total for any one event.

- ✓ Any amount we pay under this benefit, we'll pay out of your *sum insured*.

Specified items — we'll extend cover for certain items in your schedule

If your *schedule* shows that you have specified an individual item of *contents*, we'll cover that item for its *replacement value*, up to the amount your *schedule* specifies.

If you don't want to repair or replace a specified item, we'll pay you whichever is less:

- the *indemnity value* of the item
- the cost to repair the item.

- ✓ Any amount we pay under this benefit, we'll pay out of your *sum insured*.

Stolen keys — we'll pay to replace stolen keys and re-set keypads

We'll pay reasonable costs to change or replace locks and keys or change the keypad's entry code, if any of the following happen.

- A key to your *home* is stolen.
- A key to your *home* is believed on reasonable grounds to have been duplicated without your agreement following its disappearance.
- A keypad code is shared without your agreement.

We'll also pay the reasonable cost of opening any safe after its key or combination details disappear or are stolen.

We'll pay up to \$2,000 in total for any one event.

- ✓ Any amount we pay under this benefit, we'll pay out of your *sum insured*.

Storage of contents — we'll cover some contents in short-term storage

If you store your *contents* at another location, we'll cover them at that location for up to 90 days.

We'll pay the *indemnity value* up to \$20,000 within the 90-day period. The item limits in this policy still apply (see page 26).

If your *contents* are not stored in a secured unit at a commercial storage facility and under a contract in your name, we won't cover:

- *loss* or damage arising from theft (unless there is forcible or violent entry to the building or *room* where the *contents* are kept)
- unexplained *loss* or damage
- water damage.

This benefit applies if you are storing your *contents* for any reason other than a valid claim under this policy.

- ✓ Any amount we pay under this benefit, we'll pay out of your *sum insured*.

Tenant's improvements — we'll cover improvements you make to the home you rent

We'll pay up to \$5,000 for any one event for items that you own that are permanently installed and attached to the *home* you rent and live in.

If you or someone who lives with you has *home* or *contents* insurance at the same address shown on your *schedule*, we'll only pay this benefit under one policy or section of policy for each event.

- ✓ Any amount we pay under this benefit, we'll pay out of your *sum insured*.

Tertiary accommodation — we'll cover contents of your children in tertiary accommodation who normally live with you

We'll cover your children's *contents* if your children are temporarily living away from *home* in accommodation provided by a tertiary educational institution.

If the *contents* are stolen from the accommodation, we won't pay, unless there is either:

- forcible or violent entry to the building or *room* where the *contents* are kept
- actual or threatened physical violence against your child.

The most we'll pay is \$5,000 for each child. The item limits in this policy still apply (see page 26).

- ✓ Any amount we pay under this benefit, we'll pay out of your *sum insured*.

Vehicle accessories within an employer's motor vehicle — we'll cover theft of your vehicle accessories from your employer's vehicle

We'll cover your portable entertainment and navigation accessories if they are stolen from your employer's motor vehicle. The vehicle must be one that your employer owns and provides to you for your use.

This benefit only applies if there's no other cover available for these accessories under your employer's motor vehicle insurance policy.

We'll pay the *indemnity value* of the items you're claiming, up to \$1,500 in total for any one event. The additional *excess* for portable electronic equipment also applies to this benefit.

- ✓ Any amount we pay under this benefit, we'll pay out of your *sum insured*.

Cover Option – Restricted

If your *schedule* shows you have Cover Option – Restricted, we'll cover you for some types of *loss* to your *contents* while they're at your *home*. Any *loss* must happen during the *period of insurance* and arise only from the following events.

- Breakage causing a fracture through the entire thickness of mirrors, plate-glass tops on furniture, or fixed glass in furniture.
- Burglary or theft.
- Burning out by electrical current.
- Collision or impact by vehicle or animal.
- Fire, explosion, or lightning.
- Impact from aircraft or other aerial or spatial device, or items or debris dropped from them.
- Malicious damage or vandalism.
- *Natural disaster*.
- Possums entering your *home*.
- Riots, civil commotion, strikes, or labour disturbance.
- Storm or *flood*.
- Water or oil suddenly escaping or overflowing from any domestic water or heating equipment, sink, bath, toilet, or pipes installed in your *home*.

Your cover also includes the benefits below, if the circumstances they outline apply.

Your cover, including the benefits and optional benefits, is subject to the terms, limitations, exclusions, conditions, and cover limits that apply to this policy.

Benefits we include in your cover

This section explains in detail the benefits we provide, and what we'll pay for each.

- ✔ paid out of your *sum insured* + paid in addition to your *sum insured*

BENEFIT	PAGE
+ Alternative accommodation	13
✔ Authorities damage	13
✔ Change of situation and transit cover	14
✔ Credit and debit cards	14
+ Fatal injury	14
✔ Fusion of electric motors	14
+ Occupier's and personal liabilities	14
✔ Property used for trade, professional, or business use	15
✔ Specified items	16
✔ Stolen keys	16

Alternative accommodation — we'll pay for temporary accommodation if your home is uninhabitable

We'll cover your reasonably incurred extra costs for temporary accommodation if you can't live in your *home* because it is *uninhabitable* due to:

- *loss* this policy covers
- *loss* to the *home* that happens during the *period of insurance*, and the *contents* we're covering are in that *home*
- *loss* to the *home* that happens during the *period of insurance*, that is covered entirely by the Earthquake Commission
- prevention of access to the *home* by government or local authorities which is initiated during the *period of insurance* because of possible or impending damage to an otherwise safe or sanitary *home*.

The temporary accommodation must be of a similar standard to your *home*.

This cover includes boarding your *domestic pets*, storing your *contents*, and moving your *contents* to and from storage or temporary accommodation.

If you own and live in the home

If you own and live in the *home* where your *contents* are insured, we'll pay up to 12 months or temporary accommodation or \$30,000, whichever is less.

If there has been a widespread *natural disaster*, we can choose to pay beyond the 12-month period.

If you are renting the home as a tenant

If you rent the *home* where your *contents* are insured, we'll pay up to 1 month of temporary accommodation or \$5,000, whichever is less.

What we won't cover under this benefit

Under this benefit, we won't cover:

- any costs you would normally pay if your *home* was habitable, such as travel, consumables, phone charges, electricity, gas, or water supply services— or any increase in these costs associated with the temporary accommodation.
- any costs of alternative premises for your home office or healthcare practice.

Situations where this benefit won't apply

This benefit will never apply if:

- your *home* is not *uninhabitable* (other than when authorities stop you from accessing your *home*)
- we haven't agreed in writing that it's necessary for you to move out of your *home* while it's repaired or rebuilt
- the *loss* covered by the Earthquake Commission is only *loss* to land.

+ Any amount we pay under this benefit, we'll pay in addition to your *sum insured*.

Authorities damage — we'll cover damage caused to prevent other loss

We'll cover physical damage to your *contents* that government or local authorities cause to prevent *loss* that this policy covers.

The item limits in this policy still apply (see page 29).

✓ Any amount we pay under this benefit, we'll pay out of your *sum insured*.

Change of situation and transit cover — we'll cover your contents at your old and new addresses when you move

When you move house, we'll cover your *contents* at both your old and new address for up to 30 days, as long as you tell us about the new address within the 30 days.

We'll stop covering the *contents* at the previous address 30 days after the *contents* are first removed, unless we've agreed in writing, before any *loss*, to continue providing cover.

While your *contents* are being moved between your old and new *home*, we'll cover them for *accidental loss* or damage arising from fire or theft from a locked vehicle. We'll also cover your *contents* if the vehicle being used to move them overturns or is in a collision. The most we'll pay for *contents* lost or damaged in transit is \$10,000 for each event. The item limits in this policy still apply (see page 29).

- ✓ Any amount we pay under this benefit, we'll pay out of your *sum insured*.

Credit and debit cards — we'll reimburse unauthorised use

If someone uses your lost or stolen credit or debit card, we'll reimburse you for your financial loss. We'll pay up to \$1,000 for any one event.

We'll pay if all the following apply:

- You complied with the conditions the card was issued under.
- You told the police and your card issuer within 24 hours of discovering the financial loss.
- The financial loss can't be recovered from anywhere else.

- ✓ Any amount we pay under this benefit, we'll pay out of your *sum insured*.

Fatal injury — we'll make an additional payment for fatal injury from fire or burglary

We'll pay \$10,000 to your legal representative or estate if you are injured at *home* in a fire or burglary and you die of the injury within 3 months.

- + Any amount we pay under this benefit, we'll pay in addition to your *sum insured*.

Fusion of electric motors — we'll cover fusion or burnout

We'll pay to replace electric motors if they burn out or fuse.

We'll also pay for an exchange sealed compressor for motors in a sealed refrigeration or air-conditioning compression unit and for re-gassing the unit.

- ✓ Any amount we pay under this benefit, we'll pay out of your *sum insured*.

Occupier's and personal liabilities — we'll cover your legal liability if you cause loss, damage, or injury

We'll cover you for your legal liability to pay *damages* or *reparation* for *loss* to someone else's property, or *accidental bodily injury*, that happens during the *period of insurance*.

The liability must arise from an event that happens in New Zealand.

What you must do to be covered for liability for reparation

To be covered for liability for *reparation*, you must do both of the following.

- Tell us immediately if you're charged with any offence which resulted in *bodily injury* to another person or *loss* to someone else's property.
- Obtain our written approval before any offer of *reparation* is made.

Extended liability

As long as the above requirements for cover are met, we'll also extend cover for liability for *damages* and liability for *reparation* to include:

- your involvement in paid part-time baby-sitting
- using ride-on mowers, other domestic garden appliances, electric wheelchairs, and electric mobility aids
- using any canoe, kayak, surfboard, surf ski, kite surfer, paddle board, windsurfer, or boat. We won't cover liability arising from the use of any boat that has a *market value* of more than \$3,000
- non-competitively using any of the following radio-controlled scale-models.
 - Aircraft
 - Watercraft
 - Motor vehicle.

What we won't pay under Occupier's and personal liabilities

We won't pay for any punitive or exemplary damages awarded against you.

We won't pay for legal liability:

- for *loss* to property that you own or that's under your custody and control, except for your *home* when you live in it as a *tenant*
- arising from:
 - your ownership of any building or land, including your *home*
 - any business, profession, or employment
 - your ownership, possession, or use of any mechanically propelled vehicle, trailer, aircraft (including *drones*) or any boat where the *market value* of the boat is more than \$3,000
 - the ownership or possession of any animals, other than *domestic pets*.
- assumed by agreement, except if you would have been liable anyway
- where any exclusion in the 'Exclusions — things we don't cover' section applies (see pages 17 to 22).

Limits on what we'll pay for Occupier's and personal liabilities

For any one event, we'll pay:

- for *loss* to someone else's property, up to \$2,000,000
- for *bodily injury*, up to \$1,000,000.

The most we'll pay for all legal liabilities for *damages* and *reparation* is a combined total of \$2,000,000 during any *period of insurance*.

If you have other insurance with us that may cover liability for the same event, we'll still only pay up to the limits above.

We also pay legal defence costs if you are legally liable to pay damages

Where you're legally liable to pay *damages*, and we've given you our agreement in writing beforehand, we'll also pay your legal defence costs and expenses incurred. We won't pay legal defence costs and expenses in relation to an offence, or when you're legally liable to pay *reparation*.

- + Any amount we pay under this benefit, we'll pay in addition to your *sum insured*.

Property used for trade, professional, or business use — we'll cover business tools

We'll cover your tools and other items you use for trade, professional, or business purposes.

This benefit doesn't cover products, or any stock of goods or materials, whether they're raw or finished.

We'll pay up to \$2,000 in total for any one event.

- ✓ Any amount we pay under this benefit, we'll pay out of your *sum insured*.

Specified items — we'll extend cover for certain items in your schedule

If your *schedule* shows that you have specified an individual item of *contents*, we'll extend cover for that item in the following ways.

- We'll cover the item for any event we would cover under Cover Option – Premier.
- We'll cover the item while you've temporarily moved it from your *home* to use anywhere in New Zealand during the *period of insurance*.
- If the item is being repaired or replaced, we'll cover it for its *replacement value*, up to the amount your *schedule* specifies.
- If you choose not to have the item repaired or replaced, we'll cover it for its *indemnity value*, up to the amount your *schedule* specifies.

This extended cover lasts for as long as the item is specified.

- ✓ Any amount we pay under this benefit, we'll pay out of your *sum insured*.

Stolen keys — we'll pay to replace stolen keys and re-set keypads

We'll pay reasonable costs to change or replace locks and keys or change the electronic keypad's entry code, if any of the following happen.

- A key to your *home* is stolen.
- A key to your *home* is believed on reasonable grounds to have been duplicated without your agreement following its disappearance.
- A keypad entry code is shared without your agreement.

We'll also pay the reasonable cost of opening any safe after the theft or disappearance of its key or combination.

We'll pay up to \$2,000 for any one event.

- ✓ Any amount we pay under this benefit, we'll pay out of your *sum insured*.

Optional benefit – the additional cover you can choose

If you have chosen the following optional benefit, it will appear on your *schedule*. You need to have paid the additional *premium* for it to apply.

Accidental damage to contents and cover away from home

We'll cover you for *loss* to your *contents* arising from any event we would cover under Cover Option – Premier, rather than the limited events we cover under Cover Option – Restricted.

All other terms relevant to Cover Option – Restricted will still apply.

We'll also keep covering your *contents* while you've temporarily moved them from your *home* to use anywhere in New Zealand during the *period of insurance*.

We'll pay up to \$10,000 for any one event, except where we're covering items under the 'Specified items' benefit above.

Exclusions – things we don't cover

We won't cover you in these situations. These exclusions apply whether you have Cover Option – Premier or Cover Option – Restricted.

Business use

We won't cover any *loss* or liability arising from your *contents* being used for business.

This exclusion doesn't limit cover under the 'Property used for trade, professional, or business use' benefit or the 'Home office or healthcare practice' benefit.

Communicable disease

We won't cover any *loss*, damage, interruption, liability, claim, cost, expense or any other sum of any kind that arises directly or indirectly out of, is contributed to by, or is in connection with any of the following.

1. Communicable disease.
2. The actual, or perceived, fear or threat of communicable disease.
3. Actions by any person, entity or public authority to respond to, control, prevent or suppress communicable disease.

Any other sum of any kind also includes any increased or additional costs or expenses of a claim that this exclusion does not otherwise apply to.

This exclusion:

- takes priority over any other term in this policy or any endorsement (including any that might contradict it)
- applies regardless of any other cause or event contributing at the same time or in any other order to 1–3 above.

When we say communicable disease, we mean any of these things.

- Any human, animal, plant or other disease that can be transmitted directly or indirectly from any organism to another organism by means of any substance or agent, including without limitation, any:
 - virus
 - bacterium
 - parasite
 - other organism
 - any variation of any of the above, whether living or not.
- Any Infectious Disease or Quarantinable Disease as defined in or declared under the Health Act 1956.

Confiscation

We won't cover *loss*, damage, or liability in any way connected with confiscation, acquisition, designation, destruction or decision by government or local authorities.

Consequential loss

We won't cover any intangible or consequential loss of any kind, including:

- loss of use
- loss of enjoyment
- loss of value.

Damage by insects and vermin

We won't cover *loss* caused by insects or vermin — except possums.

However, if there's resulting *loss* to other items of *contents* caused by the excluded *loss*, we'll cover it (unless it's excluded under another part of this policy).

Damage during cleaning, repair, renovation, or restoration

We won't cover any *loss* caused by any cleaning process, renovation, repair, or restoration — but this only excludes the property that has undergone that process.

However, if there's resulting *loss* to other items of *contents* caused by the excluded *loss*, we'll cover it (unless it's excluded under another part of this policy).

Defective workmanship

We won't cover *loss* caused by poor or defective workmanship.

However, if there's resulting *loss* to other items of *contents* caused by the excluded *loss*, we'll cover it (unless it's excluded under another part of this policy).

Defects

We won't cover *loss* caused by any defect in design or inherent fault.

However, if there's resulting *loss* to other items of *contents* caused by the excluded *loss*, we'll cover it (unless it's excluded under another part of this policy).

Deliberate damage by anyone living at your home

We won't cover *loss* caused by burglary, theft, or malicious, intentional, or deliberate damage committed by anyone renting, living, or staying in your *home*.

However, if your *home* is *tenanted*, we'll cover any *loss* to *contents* from fire or explosion caused by malicious, intentional, or deliberate damage by *tenants*.

Deliberate or reckless acts

We won't cover any *loss*, damage, or liability in any way connected with you or anyone else this policy covers acting, or failing to act, in a way that is:

- deliberate
- intentional
- knowing
- wilful
- reckless.

This exclusion applies whether the act or failure to act was criminal or not.

Electronic data

We won't cover any *loss*, damage, or liability in any way connected with the *loss* of or damage to any electronic data.

We won't cover any *loss* of use or reduction in functionality in connection with the *loss* of electronic data.

This also includes any electronic data you buy in place of an item you could buy in a non-electronic format.

Excesses

We won't cover any *excesses*.

Fire and Emergency Act 2017

We won't cover you where your liability arises directly or indirectly from any fire you intentionally lit that didn't comply with either:

- the Fire and Emergency Act 2017
- any other statutory or local body requirements governing the lighting of fires.

Gradually operating causes

We won't cover *loss* caused by the action of micro-organisms, mould, mildew, rot, fungi, or any other gradual cause.

We won't cover *loss* caused by corrosion or rust.

This exclusion doesn't limit cover under the 'Gradual damage' benefit.

Household pets

We won't cover *loss* caused by any pets scratching, chewing, tearing, or soiling.

This exclusion only applies if you don't live in your *home*.

Hydrostatic pressure

We won't cover any loss to swimming and spa pools caused by hydrostatic pressure.

Land

We won't cover any of the following.

- *Loss* to land.
- Costs associated with stabilising land, even where it's necessary to prevent or lessen *loss* to your *contents*.
- Costs associated with erecting or upgrading improvements to land, even where it's necessary to prevent or lessen *loss* to your *contents*.
- *Loss* caused by subsidence, settling, ground heave, shrinkage, expansion, or erosion.

Lifting or moving your home

We won't cover *loss* that is in any way connected with lifting or moving your *home*.

Loss that's covered by ACC

We won't cover any amount that anyone (including the victim of an offence) can claim under the Accident Compensation Act 2001. This includes if:

- the victim hadn't made an ACC claim, or didn't make an ACC claim within the time required under the Act
- ACC declined the claim or limited their liability for any reason.

Mechanical or electrical breakdown

We won't cover *loss* caused by either:

- mechanical or electrical breakdown
- inability to operate any mechanical or electrical device this policy covers.

This exclusion doesn't apply to *loss* caused by actual burning out as a direct result of an *accidental* external cause, or if the loss arises from:

- impact
- earthquake or *flood*
- fire or lightning

- an external power surge that originated outside of the *home* the *contents* are located in, or outside of any other location your *contents* are in while they are temporarily removed from the *home*
- volcanic eruption
- malicious acts.

We never cover *loss* where arcing occurs in the ordinary working of any lighting or heating element, fuse, protective device, or electronic contact.

However, if there's resulting *loss* to other items of *contents* caused by the excluded *loss*, we'll cover it (unless it's excluded under another part of this policy).

Nuclear activity

We won't cover *loss*, damage, or liability in any way connected with nuclear weapons, ionising radiation, or contamination by radioactivity from nuclear fuel, or the combustion of waste from nuclear fuel.

Removed Property

Contents you've permanently moved or are moving between homes

We won't cover *loss* to *contents* you've permanently removed from your *home* or are moving between *homes*, including loading onto and unloading from a vehicle.

This exclusion doesn't limit cover under the 'Change of situation and transit cover' benefit.

Contents you're keeping elsewhere or storing

We won't cover *loss* to *contents* you're keeping at any other address or loaning to anyone.

We also won't cover *loss* to *contents* you've moved anywhere for storage.

This exclusion doesn't limit cover under the 'Alternative accommodation' benefit, 'Change of situation and transit cover' benefit or the 'Storage of contents' benefit.

Contents you've moved to sell

We won't cover *loss* to *contents* you've moved to any place to sell, exchange for monetary benefit, or exhibit.

Some events in the first 72 hours of this policy

We won't cover any *loss* that happens during the first 72 hours of the policy, if the *loss* is caused by storm, *flood*, landslip, bush fire or volcanic activity.

This exclusion only applies when you first take out this policy. This exclusion doesn't apply if this policy starts immediately after another policy that insured your *contents* against storm, *flood*, landslip, bush fire or volcanic activity.

Structural changes we haven't agreed to

We won't cover *loss* that's in any way connected with any structural changes to your *home*, like additions, alterations, or removing any external walls, roof cladding, windows, or doors.

However, we'll cover you if you told us about the work before it began, and we agreed in writing to keep covering you.

Terrorism

We won't cover *loss*, damage, or liability in any way connected with any act of terrorism. This includes any act of terrorism in any way connected to pollution, contamination, or explosion that is:

- biological
- chemical
- radioactive
- nuclear.

An act of terrorism means any act which:

- may include the use of force or violence, or the threat of its use; and
- is carried out or arranged by any person or group(s) of people, whether acting alone or on behalf of or in connection with any organisation(s) or government(s).

From its nature or context, the act:

- is done for, or in connection with, political, religious, ideological, ethnic or similar purposes; and
- may include the intention to influence any government or to put fear in the public or any section of the public.

Tyres

We won't cover *loss* to the tyres of bicycles, and other mechanically propelled vehicles this policy covers, caused by:

- applying brakes
- punctures
- cuts
- bursts or bursting.

This exclusion doesn't apply if either:

- the bicycle or vehicle suffers other *loss* in an *accident*
- a person that this policy doesn't cover deliberately caused the *loss*.

However, if there's resulting *loss* to other items of *contents* caused by the excluded *loss*, we'll cover it (unless it's excluded under another part of this policy).

Unoccupied homes

We won't cover any *loss* to your *contents* while your *home* is:

- *unoccupied*
- unattended, if you normally use it as a holiday *home* or weekend *home*.

However, we'll cover your *contents* if we know the *home* is a holiday *home*, or we agreed in writing to cover you while your *home* was *unoccupied*.

All of the following must be met.

- Your *home*, its lawns, and its gardens are kept tidy.
- All external doors and windows are kept locked.
- All papers and mail are collected regularly.
- Your *home* is under regular supervision.

If you normally live in your *home*, but your travel or medical commitments mean it's *unoccupied* for more than 60 days, we'll keep covering your *contents* for an additional 30 days. You must still meet the conditions above.

Unsecured outboard motors

We won't cover *loss* to or arising from theft of outboard motors, if the motors aren't:

- securely locked to a boat
- stored in a securely locked part of a boat
- placed in a securely locked building.

Vibration

We won't cover *loss* caused by vibration, weakening, or removal of support.

War

We won't cover *loss*, damage, or liability in any way connected with:

- war
- invasion
- acts of foreign enemies
- hostilities or warlike operations (whether war is declared or not)
- civil war
- civil commotion assuming proportions of or amounting to an uprising
- military uprising
- popular uprising
- mutiny
- rebellion
- revolution
- insurrection
- military or usurped power.

Wear and tear

We won't cover *loss* caused by wear and tear.

However, if there's resulting *loss* to other items of *contents* caused by the excluded *loss*, we'll cover it (unless it's excluded under another part of this policy).

Making a claim

If something happens and you think you may need to make a claim, first make sure everyone is safe.

Then, contact your insurance adviser or us as soon as possible.

Once we have all the information we need, we'll decide the best way to advance your claim.

What you must do if something happens that might lead to a claim

If anything happens that might lead to a claim under this policy, you must do all the following.

- Tell the Police if there's been theft, burglary, or vandalism.
- Tell your insurance adviser or us about what's happened.
- Take all reasonable steps to minimise the *loss*.
- Send us any communications you get about an event that might lead to a claim.
- Obtain our permission before you start repairs.
- Let us inspect any damaged *contents*. If you need to immediately remove or destroy *contents* because of health and safety, take photos of the damage and send them to us.
- Provide us any information or help we may need, including proof that you own the property you're claiming for and evidence of its value. Proof could be receipts, bank or credit card statements, valuations, photos, or contracts of sale.
- Help us take any recovery action we choose against anyone we consider responsible for the *loss*.
- At your cost, cooperate with our assessors, investigators, lawyers, and anyone else we appoint to help us. This includes attending meetings with them when we need you to.

If you don't fulfil these responsibilities

If you don't fulfil the responsibilities outlined above, we may:

- reduce the amount we pay you
- refuse to pay, or decline, your claim
- require you to pay back to us anything we've paid for the claim.

What you must do to help us settle your claim

Obtain our permission before you incur expenses or negotiate claims

You must obtain our written permission before you incur any expense or negotiate, pay, settle, admit, reject, or make any agreement about any claim.

We will act in your name

In your name, we can:

- take any proceedings necessary to use your legal right of recovery from anyone else
- take over, defend, and settle any claim against you for *damages*.

If we act in your name, we'll do so at our expense. You must provide all reasonable help and cooperation, at your cost.

When we accept your claim, your damaged contents become our property

When we accept your claim, any damaged items of *contents* become our property to dispose of or salvage.

We will share and collect information about your claim

You allow us to share information with third parties about any claim you make under this policy. You also allow us to get information from third parties that's relevant to any claim you make under this policy.

You must complete documents agreeing settlement

Before we settle your claim, you must complete documents describing our settlement for your claim.

Excess – you will have to pay an excess

The *excess* is the amount you must pay towards the cost of any claim.

The *excess* forms the first part of any *loss* you're claiming for.

We'll take the *excess* away from the amount of your claim, not from any policy limit.

If *loss* arises from multiple incidents, occasions, or events, the *excess* (or each relevant *excess*) applies to each incident, occasion, or event that causes *loss*.

One event, one excess

Usually, you'll pay an *excess* for every claim. However, if you need to claim under more than one policy with us for *loss* caused by a single event at the same location, you'll only pay one *excess*. This will be the largest applicable *excess* of all your policies.

Different types of excess can apply

More than one type of *excess* could apply – the specific circumstances of your claim will determine the total value of the *excess* you need to pay. If more than one type of *excess* applies, they'll apply cumulatively – they'll be added together to reach the total *excess*. Any amount shown on your *schedule* or described in this policy wording as an *excess* could apply.

The following additional *excesses* apply, unless the *loss* arises from fire, *flood*, or *natural disaster*.

- \$250 for each event, if you let your *home* to *tenants* other than you.
- \$1,000 for each event, if you make your *home* available to anyone for casual use in return for any form of payment.

An additional \$150 *excess* applies to any claim for portable electronic equipment that's lost or stolen from your motor vehicle.

An additional \$250 *excess* applies to any claim for *loss* to *contents* if they are stolen during a burglary at your *home* and all the following apply.

- You've told us you have a security alarm system, which we have given you a discount for.
- The alarm was not turned on and/or not activated.
- You weren't at *home* at the time of the *loss*.

How we'll settle your claim under Cover Option – Premier

If your *contents* suffer a *loss* which we accept under this policy, we may choose to settle your claim in one of the following ways. The most we'll pay for *loss* to your *contents* is the *sum insured* shown on your *schedule*.

We'll decide how to advance your claim

We'll decide the best way to advance your claim, including inspecting any damage, choosing the repairer or supplier, and arranging the repair or replacement of the *contents*.

If we choose to repair your *contents*, we'll get independent quotes from our approved repairers or suppliers. You can recommend repairers or suppliers to provide quotes for us to consider. We'll choose who will repair your *contents*, oversee any repairs, and keep you up to date with what's happening.

We'll pay replacement value for most items

We'll pay the *replacement value* for most *contents*. However, we'll pay *indemnity value* for the items listed below.

We'll pay indemnity value for the following items

We'll pay *indemnity value* for:

- clothing and footwear
- video tapes, audio tapes, records, and discs
- books and magazines
- sports equipment more than 2 years old
- camping, fishing, and diving equipment more than 2 years old
- bicycles (including e-bikes) more than 3 years old
- *drones* more than 3 years old
- laptops, tablets, mobile or smart phones, or any other similar handheld electronic devices that are more than 3 years old and can do any of the following.
 - Communicate with other people or devices
 - Receive, run, or display and store executable data programmes, or applications
- *contents* at a *home* you own, if you rent your *home* to anyone who is not entitled to cover under this policy.

The most we'll pay for some items

This table shows the most we'll pay for the listed items, unless they are specified on your *schedule* for another amount as per cover under the 'Specified items' benefit (page 10).

The limits include the item and its accessories.

Item	Limit on what we'll pay
Each unspecified item, pair, or set of jewellery or watches	\$3,000 For any one event, we'll pay up to a maximum of 15% of the <i>sum insured</i> on your <i>schedule</i> (excluding specified items of jewellery and watches) or \$15,000 — whichever is greater
Each item of photographic, digital, and video camera equipment We count a camera body and a standard lens as one item, unless separately specified on the <i>schedule</i> . Any extra lens not permanently attached to a camera body, or one that's designed to be interchangeable, we count as its own item.	\$3,000, unless specified otherwise on your <i>schedule</i>
Any bicycle (including any e-bike)	\$3,000, unless specified otherwise on your <i>schedule</i>
Any <i>drone</i>	\$3,000, unless specified otherwise on your <i>schedule</i>
Any canoe, kayak, surfboard, surf ski, kite surfer, paddle board, or windsurfer	\$3,000, unless specified otherwise on your <i>schedule</i>
Any boat (other than canoes, kayaks, surfboards, surf skis, kite surfers, paddle boards, or windsurfers)	\$3,000 Under this policy we won't cover any boat that has a <i>market value</i> of more than \$3,000
Motor and marine parts and accessories, including children's car seats, while they're out of any vehicle or boat	\$2,000 in total
Remote-controlled scale models	\$2,000 in total
Each coin, card, or stamp in a collection	\$1,000 \$3,000 in total for any collection of coins, cards, or stamps, unless specified otherwise on your <i>schedule</i>
Unset precious stones or minerals, gold or silver bullion or ingots, and precious metals	\$1,000 in total, unless specified otherwise on your <i>schedule</i>
All money, negotiable securities, certificates, documents, and travel tickets	\$1,000 in total

We settle some claims in specific ways

If you don't want to repair or replace an item

If you don't want to repair or replace an item, we'll pay the lesser of the *indemnity value* or the cost of repairs.

This doesn't apply to unspecified jewellery and watches (see below).

If you don't repair or replace unspecified watches or jewellery

If you don't want to repair or replace an unspecified item of jewellery or watch, we'll pay the lesser of the *market value* or 50% of the *replacement value*.

The item limits for jewellery or watches will still apply (see page 26).

We'll only replace floor coverings, drapes, curtains, and blinds in the room where the loss happens

We'll only pay to replace damaged floor coverings, drapes, curtains, and blinds in the *room* where the *loss* happened.

We'll only pay for consumables you had when the loss happened

If any consumables suffer *loss*, we'll only pay for the proportion you had when the *loss* happened.

If damaged items are part of a group, we'll only pay for those damaged items

If items that suffer *loss* are part of a group of *similar items*, we'll only pay for those items that actually suffered *loss*. We'll pay up to the value of or cost to replace those items. This condition doesn't apply to jewellery.

We don't have to exactly replace, repair, reinstate or rebuild items.

Repairs to furniture

We'll only repair or pay for items that actually suffer *loss*. If the items that suffer *loss* are part of a group of *similar items*, we'll pay up to the value of or cost to replace those items only.

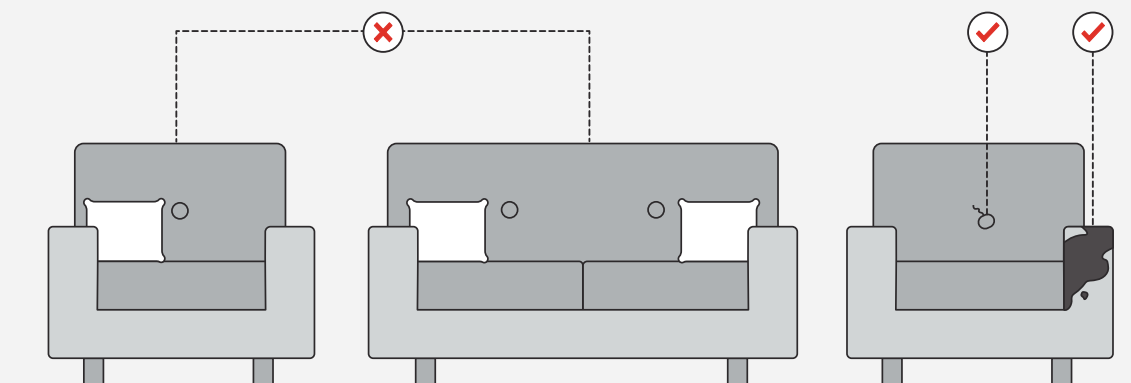

Obtain pre-loss valuations for any specified jewellery

If you have any specified items of jewellery on your *schedule*, you must support any claim for burglary, theft, or unexplained *loss* with a pre-loss valuation for each item you're claiming for.

If you don't have a pre-loss valuation for the specified item being claimed for, it can affect the claim settlement for that item.

Any pre-loss valuation must be from a suitably qualified jewellery valuer who is a member of a New Zealand jewellery valuers or appraisers society.

Keep higher valued specified jewellery and watches in a locked safe when not in use

You must keep the following items in a locked safe in certain circumstances:

- any individual specified item of jewellery or watch worth over \$50,000
- all specified items of jewellery or watches, if their total value is over \$100,000.

You must keep these specified items in a locked safe when you're either:

- not wearing or carrying the items
- absent from the building you leave the items in.

The safe must be all of the following.

- Manufactured by a reputable safe manufacturer.
- Of a standard sufficient to protect the specified items from burglary.
- Securely anchored to the floor or wall, following the manufacturer's installation instructions.

If you don't follow these requirements, we won't cover the items for burglary, theft, or unexplained *loss*.

Costs we'll pay that are associated with your claim

Removal of debris

We'll pay reasonable costs incurred to remove the *contents* debris from your *home*. We must agree to any costs in advance.

- + Any amount we pay under this section, we'll pay in addition to your *sum insured*.

The maximum we'll pay for your claim

The maximum amount we'll pay is the following list, added together.

- The *sum insured* shown on your *schedule* (including benefits paid from within your *sum insured*).
- Any GST that you've paid or is payable on the *sum insured*.
- Any amounts we are required to pay under these benefits:
 - Alternative accommodation (page 6)
 - Fatal injury (page 7)
 - Occupier's and personal liabilities (page 9).
- Any amount we pay for Removal of debris as outlined under the heading 'Costs we'll pay that are associated with your claim' above.

How we'll settle your claim under Cover Option – Restricted

If your *contents* suffer a *loss* which we accept under this policy, we'll pay either of the following:

- the *replacement value* of furniture, furnishings and home appliances up to 10 years of age
- the *indemnity value* of all other *contents*.

Any payment we make will be limited to the *sum insured* shown in the *schedule*. However, any items of *contents* that you specify under the 'Specified items' benefit on page 16 will be covered for their *replacement value* as outlined in the benefit.

The most we'll pay for some items

This table shows the most we'll pay for the listed items, unless they are specified on your *schedule* for another amount under the 'Specified items' benefit (page 16).

The limits include the item and its accessories.

Item	Limit on what we'll pay
Each unspecified item, pair, or set of jewellery or watches	\$3,000 For any one event, we'll pay up to a maximum of 15% of the <i>sum insured</i> on your <i>schedule</i> (excluding specified items of jewellery and watches) or \$15,000 – whichever is greater
Each item of photographic, digital, and video camera equipment We count a camera body and a standard lens as one item, unless separately specified on the <i>schedule</i> . Any extra lens not permanently attached to a camera body, or one that's designed to be interchangeable, we count as its own item.	\$3,000, unless specified otherwise on your <i>schedule</i>
Any bicycle (including any e-bike)	\$3,000, unless specified otherwise on your <i>schedule</i>
Any <i>drone</i>	\$3,000, unless specified otherwise on your <i>schedule</i>
Any canoe, kayak, surfboard, surf ski, kite surfer, paddle board, or windsurfer	\$3,000, unless specified otherwise on your <i>schedule</i>
Any boat (other than canoes, kayaks, surfboards, surf skis, kite surfers, paddle boards, or windsurfers)	\$3,000 Under this policy we won't cover any boat that has a <i>market value</i> of more than \$3,000
Motor and marine parts and accessories, including children's car seats, while they're out of any vehicle or boat	\$2,000 in total
Remote-controlled scale models	\$2,000 in total
Each coin, card, or stamp in a collection	\$1,000 \$3,000 in total for any collection of coins, cards, or stamps, unless specified otherwise on your <i>schedule</i>
Unset precious stones or minerals, gold or silver bullion or ingots, and precious metals	\$1,000 in total, unless specified otherwise on your <i>schedule</i>
All money, negotiable securities, certificates, documents, and travel tickets	\$1,000 in total

We settle some claims in specific ways

If you don't repair or replace unspecified watches or jewellery

If you don't want to replace or repair any unspecified item of jewellery or watch, the most we'll pay up to is 50% of the *indemnity value*.

The item limits for jewellery or watches on will still apply (see page 29).

We'll only pay for floor coverings, drapes, curtains, and blinds in the room where the loss happens

We'll only pay for damaged floor coverings, drapes, curtains, and blinds in the *room* where the *loss* happened.

We'll only pay for consumables you had when the loss happened

If any consumables suffer *loss*, we'll only pay for the proportion you had when the *loss* happened.

If damaged items are part of a group, we'll only pay for those damaged items

If items that suffer *loss* are part of a group of *similar items*, we'll only pay for those items that actually suffered *loss*. We'll pay up to the value of or cost to replace those items. This condition doesn't apply to jewellery.

We don't have to exactly replace, repair, reinstate or rebuild items.

Repairs to furniture

We'll only repair or pay for items that actually suffer *loss*. If the items that suffer *loss* are part of a group of *similar items*, we'll pay up to the value of or cost to replace those items only.

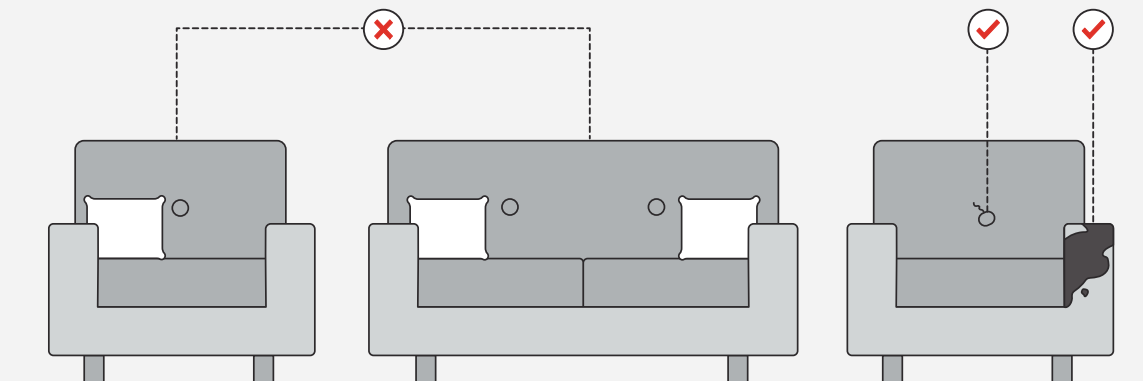

Obtain pre-loss valuations for any specified jewellery

If you have any specified items of jewellery on your *schedule*, you must support any claim for burglary, theft, or unexplained *loss* with a pre-loss valuation for each item you're claiming for.

If you don't have a pre-loss valuation for the specified item being claimed for, it can affect the claim settlement for that item.

Any pre-loss valuation must be from a suitably qualified jewellery valuer who is a member of a New Zealand jewellery valuers or appraisers society.

Keep higher valued specified jewellery and watches in a locked safe when not in use

You must keep the following items in a locked safe in certain circumstances:

- any individual specified item of jewellery or watch worth over \$50,000
- all specified items of jewellery or watches, if their total value is over \$100,000.

You must keep these specified items in a locked safe when you're either:

- not wearing or carrying the items
- absent from the building you leave the items in.

The safe must be all of the following.

- Manufactured by a reputable safe manufacturer.
- Of a standard sufficient to protect the specified items from burglary.
- Securely anchored to the floor or wall, following the manufacturer's installation instructions.

If you don't follow these requirements, we won't cover the items for burglary, theft, or unexplained *loss*.

Costs we'll pay that are associated with your claim

Removal of debris

We'll pay reasonable costs incurred to remove the *contents* debris from your *home*. We must agree to any costs in advance.

- + Any amount we pay under this section, we'll pay in addition to your *sum insured*.

The maximum we'll pay for your claim

The maximum amount we'll pay is the following list, added together.

- The *sum insured* shown on your *schedule* (including benefits paid from within it).
- Any GST that you've paid or is payable on the *sum insured*
- Any amounts we are required to pay under these benefits:
 - Alternative accommodation (page 13)
 - Fatal injury (page 14)
 - Occupier's and personal liabilities (page 14).
- Any amount we pay for Removal of debris as outlined under the heading 'Costs we'll pay that are associated with your claim' above.

What your responsibilities are

This section outlines the responsibilities you, and anyone else insured under this policy, must meet.

Information given to us must be correct

Your proposal, application, or declaration form is the basis of this contract.

All statements and information you give us, or anyone gives us on your behalf, must be complete and correct. This includes statements and information:

- in any proposal, application, or declaration – whether we get the statements and information verbally, electronically, or in printed form
- that support this policy or any claim.

If you give incorrect or false information in relation to your claim, or if your claim is fraudulent in any way, we won't pay the claim. If your claim is fraudulent, your policy automatically ends – we will cancel your policy from the date you made the claim or gave us the false information.

If you give us incorrect or incomplete information, or if information is withheld, and your claim is declined or we *avoid* your policy, this may affect your ability to obtain insurance in the future.

You have a duty of disclosure

You have a duty of disclosure, which means you must tell us everything we'd consider material to decide:

- whether to issue, renew, or change this policy
- the terms on which we'd issue, renew, or change this policy, including the *premium* we charge.

Your duty of disclosure applies each time you renew or change this policy. If you don't meet your duty of disclosure, we can refuse a claim, reduce any claim payment, or *avoid* the policy. This may affect your ability to obtain insurance in the future.

Tell us if anything changes

Tell us straight away if there's a change that could affect your cover, our decision to insure you, or the *premium* we charge. Some examples of when you might need to do this are:

- you're going to leave your *home unoccupied*
- you or someone living with you is convicted of a criminal offence.

If you're not sure whether something is important, tell us anyway. If you don't keep us up to date, we can refuse a claim, or reduce any claim payment, or *avoid* the policy.

If we avoid your policy

If we *avoid* your policy, we treat it as though it never existed. You'll have to pay back any claim payments we have made to you, and we'll refund you any *premium* you have paid to us.

This might mean you find it difficult to get other insurance in the future.

You're responsible for setting your sum insured

You're responsible for setting your *sum insured*. You must ensure at all times it is sufficient to cover *loss* or damage to your *contents*.

You must take all reasonable steps to prevent loss

You must, at your cost or expense, take all reasonable steps to prevent *loss* and keep any *contents* covered by this policy in good condition. We always have the right to examine property this policy covers.

You must also try to avoid any *loss* that you could be held legally liable for.

We won't cover *loss* or legal liability in the event that you are reckless or grossly negligent.

Reckless or grossly negligent means you've failed to act in the way a reasonable person would, given the circumstances you faced when the *loss* happened.

If you're paid reparation, you may need to pay it to us

If anyone covered by this policy is paid *reparation* for *loss* or damage to property that we are paying (or have paid) a claim for, you must tell us. You must give us the *reparation* payments to repay the claim payments that we have made, up to the amount of the *reparation* received.

You can't pass on your rights or interests under this policy

Without our prior written agreement, you can't assign, or attempt to assign, either of the following to any other party.

- This policy or your interest in it.
- Your rights to any claims proceeds under this policy.

Policy conditions and other important information

Your premium

Your *premium* is the payment you make in exchange for your insurance cover. Your *premium* is detailed on your *policy schedule*. You will pay your *premium* monthly or annually, depending on the policy you have chosen.

Your premium must be paid up to date before we'll pay a claim

If you need to make a claim and you have *premium* that is less than 60 days overdue, we may withhold the claim payment until you've paid the overdue *premium*.

Your policy ends if your premium is more than 60 days overdue

To ensure that you have an opportunity to maintain cover in the event that a monthly *premium* payment has not been made to us, we will attempt again to collect the outstanding *premium* from your nominated bank account the month following.

If your *premium* is overdue by more than 60 days (two consecutive months), your insurance cover under this policy ends and a notification of policy cancellation will be issued.

Your cover reduces after a claim, until your claim is settled

If we pay a claim for *loss* under this policy, your policy continues. However, the amount of money available to pay future claims out of the *sum insured* reduces by the value of the *loss*.

We'll restore the amount of cover in line with either:

- the replacement or repair of the *contents*
- the payment we make to you for the *loss*.

Before we restore the amount of your cover, both of the following things must happen.

- You must pay any extra *premium* that we may charge.
- We must be satisfied that the *sum insured* shown on your *schedule* is a reasonable estimate of the *replacement value* or *indemnity value* of your *contents*.

We'll only restore your cover once during the *period of insurance*, unless we agree otherwise in writing. If your claim is for the *total loss* of your *contents*, or if we pay the total *sum insured*, this condition won't apply, and your policy will end.

How your policy can be cancelled

You can cancel your policy

You have a cooling-off period if you change your mind.

When you first purchase this policy, you can cancel it within 30 days if you change your mind. We'll refund all the *premium* you've paid if you haven't made a claim.

You can cancel after the cooling-off period

You can cancel your policy at any time after the 30-day cooling-off period. If you haven't made a claim, we'll refund any *premium* you've already paid for insurance cover after the cancellation date.

We can cancel your policy

We can write to you to cancel your policy

We can cancel this policy at any time by writing to either:

- you at the address or email address on our records
- your insurance adviser.

Your policy will be cancelled from 4.00pm on the 14th day after we send the letter. We will refund any *premium* you've already paid us for cover after the effective date of the cancellation.

We'll cancel your policy if you make a fraudulent or false claim

If you make a fraudulent or false claim, this policy automatically ends. We don't need to cancel it in writing, but we may confirm to you in writing that it was automatically cancelled at a particular time. We refund any *premium* you have already paid for cover after the cancellation date.

We may offer to renew your policy

The way we renew your policy depends on whether it is monthly or annual.

If you have an annual policy

Before your annual policy expires, we may invite you to renew it. Before renewing, it is very important that you check all information on the renewal invitation to confirm that your insurance details are still correct and continue to meet your requirements.

If you have a monthly policy

Monthly policies do not have an annual renewal date. They expire every month on the same day that you took out your policy. It is very important that you review your cover regularly to make sure that it still meets your requirements.

To maintain cover, you need to make sure that you continue to make monthly *premium* payments.

We may automatically adjust your sum insured at renewal

When we renew your policy, we consider factors that can influence the cost of repairing or replacing items of *contents*.

As a result, we may adjust the *sum insured* for your *contents*. If we do, we'll show your new *sum insured* on your *schedule*, and adjust your *premium* accordingly.

We don't guarantee, represent or advise that any change to your *sum insured* will be enough to compensate you fully for any *loss* or damage. You must always ensure your *sum insured* is enough to cover *loss* or damage to your *contents*, and associated costs.

We don't cover you if you breach these terms

To be covered under your policy, you must comply with the terms and conditions outlined in this policy wording.

If we find that anyone insured by your policy has breached any of these terms or conditions, we can refuse a claim, or reduce the payment.

However, nothing in this policy wording affects our rights or yours under common law, including our right to *avoid* your policy for not making full disclosure in accordance with your duty of disclosure.

This policy can cover multiple parties as joint insureds

This policy is a joint policy if your *schedule* shows joint names, or includes the name of a Trust, as being insured.

We view each insured person as acting with the explicit permission of any other. You each have the right to change this policy, make or settle a claim under this policy, or cancel this policy.

Any breach of the policy terms or conditions by one person will prevent all insured people from claiming under this policy.

We may change terms of this policy

If we can no longer obtain or retain full reinsurance protection from any *natural disaster* this policy covers, we may change the terms of this policy, including the *excess*.

We'll send a letter or email to the latest address we have for you, or to your insurance adviser. The change takes effect at 4pm on the 14th day after we send the letter.

How GST applies when we pay a claim

Dollar figures for benefits, excesses, and limits to items (including specified items) in this policy include GST. However, we'll pay GST that is paid or payable on top of the *sum insured*.

We only pay once if more than one benefit could apply

Some benefits under this policy can only be used once per event, even if you have more than one policy or section of a policy with us that has the same benefit.

This condition applies if you, or someone you live with, has any of the following benefits with us under more than one policy:

- Alternative accommodation
- Occupier's and personal liabilities
- Stolen keys
- Tenants' improvements

We don't cover you if you have other insurance

We won't cover you for *loss* or liability where insurance cover is provided by another insurer for the same loss or liability, except where the 'Fatal injury' benefit applies. We won't contribute towards any claim under any other policy.

If your contents are secured by an interested party

If any item of your *contents* is under a hire purchase contract, or secured by another kind of financial agreement, we may make any claim payment to the interested party. This will meet our responsibilities under this policy.

Where required, we'll share personal information about you with any party that holds a financial interest in your *contents*.

We don't cover parties with a financial interest under this policy, and those parties can't make claims.

New Zealand law applies to this policy

This policy is governed by New Zealand law and New Zealand courts have exclusive jurisdiction over any legal proceedings about this policy.

When this policy mentions an Act of New Zealand Parliament, this includes any substitution, amendment, or replacement of the Act. If the Act has been repealed and there is no substitution or replacement, we mean any part of an Act with substantially the same purpose and function. It includes the regulations under the Act.

We'll put details of your claims on the Insurance Claims Register

In buying this policy, you allow us to put details of any claims you make on the Insurance Claims Register (ICR) so other insurers can see them. You also allow us to obtain personal information and details of claims you've made from the ICR.

The ICR is a database of insurance claims. It helps prevent insurance fraud by enabling insurance companies to share details of claims. The ICR is operated by Insurance Claims Register Limited (ICR Ltd), PO Box 474, Wellington 6140.

Definitions

This section defines some words and phrases that have specific meanings in this document. When we use any of these words or phrases, we use *italics*, and we mean the definition we give in this section.

Accident, accidental, and accidentally

A sudden and unforeseen event not intended or expected by you.

Avoid (a policy)

We'll treat your policy as though it never existed, in accordance with the legal principles which govern the duty of disclosure and its remedies.

Bodily injury

Bodily injury (including death), illness, disability, disease, shock, fright, mental anguish, or mental injury to another person.

Contents

Anything in your:

- possession or located at the *home*, belonging to you or hired by you
- custody or control for which you are responsible, that is not insured elsewhere.

Contents doesn't include any of the following.

- Mechanically propelled vehicles, trailers, caravans, or aircraft (except ride-on mowers and other domestic garden appliances, electric wheelchairs and electric mobility aids, *drones* while they are not in use, and remote-controlled scale models).
- Vehicle accessories in or on a vehicle.
- Vehicle keys or vehicle remote controls.
- Entertainment and communications systems that are in or on a vehicle, including any parts that attach to these systems.
- Navigation systems or radar detectors in or on a vehicle, including any parts that attach to them.
- Trees, shrubs, and plants (other than pot plants).
- Fixtures, fittings, sculptures, or artwork (and their accessories) permanently attached to the *home* or to land.
- Contents used in any way for professional or business purposes, except for:
 - laptop computers, tablets, mobile or smart phones, or any other similar handheld electronic device that you also use for personal use
 - the cover provided by the 'Property used for trade, professional or business use' benefit and the 'Home office or healthcare practice' benefit.
- Contents normally housed in an address not named on the *schedule*.
- Any item of contents that you have sold, gifted, or given away, that is no longer in your possession, or any item which you have taken ownership of or responsibility for, but you have not yet taken possession of.
- Any artificial body parts, surgical implants, or attachments that are permanently fitted to you or to any animal.
- Any animal.
- The *home*.
- *Drones* while they are in use.

Damages

Money you have to pay because of a judgment against you, or a settlement we negotiate. Damages can include the other party's costs, and interest.

Damages does not include:

- punitive or exemplary damages
- *reparation*
- fines
- taxes
- any other kinds of penalty or compensation, financial or not
- any other payment that is unlawful to insure against.

Domestic pets

Any animal that's tamed and kept for pleasure and companionship. It doesn't include any animal that is:

- not usually found living in urban households
- kept as a working or sporting animal
- kept for breeding or for any economic purpose.

Drone(s)

Any aerial device that's unmanned, unpiloted, or remotely operated.

Excess(es)

The amount you must pay towards the cost of any claim.

Flood

The inundation of land by water that has either:

- escaped or been released from the normal confines of the sea, a watercourse, reservoir, pond, dam, or lake
- run off, accumulated, or pooled.

This definition does not apply if it is only your property that is inundated.

Home

The dwelling, including residential flat or holiday home, which is:

- owned by you
- used for residential purposes
- located within the residential boundaries
- at the address shown on your *schedule*.

Home includes the following items shown on your *schedule* which are owned by you, used for *residential purposes*, and located within the *residential boundaries* of the address.

- Each additional self-contained dwelling unit that's capable of being lived in and is intended by you to be, or actually is, the *home* of one or more persons (if your *schedule* specifically indicates that the *home* includes additional dwelling units).
- Any separate outbuildings that are not self-contained or capable of being lived in, and any garages.
- Permanent decks.
- Greenhouses and garden sheds, patios, pergolas, and built-in furniture.
- Aerials and satellite dishes that are attached to the *home*.
- Fixed floor coverings (floating, glued, tacked, or smooth edged).
- Coverings fixed to the ceiling or wall.
- Curtains, drapes, and blinds.

- Fixed light fittings and appliances permanently wired or plumbed to a gas, plumbing, or electricity supply.
- Letter boxes, exterior blinds and awnings, fixed clotheslines, and built-in barbeques.
- Septic tanks, heating oil tanks, service tanks, water tanks, and their fixed pumps and systems.
- Permanent spa pools or swimming pools, including their fixtures, covers, pipes, and fixed pumps.
- Walls, fences, and gates.
- Solar panels.
- Gas pipes, fresh-water pipes, underground drainage, and sewerage pipes.
- Cables and poles associated with electricity, data, and telephone services.
- Any driveways, paths, patios, bridges, paving, and tennis courts.
- Any private road, lane, right-of-way, access way, or bridge (including associated guttering, drains, piping, cables, and lighting) providing access to a driveway that you own, or share with other residential property owners, and for which you're responsible.
- Permanently installed ornamental fishponds and water features connected to the dwelling's water supply.
- Sculptures and artwork that are permanently fixed to buildings or land.
- Your share in any walls (except retaining walls), fences, gates, pipes, cables, or driveways that you jointly own with other property owners.
- Any part of the home used as a home office or healthcare practice.

Indemnity value

One of the following.

- For a total *loss* – the *market value* of the *contents* immediately before the *loss* occurred.
- For a partial *loss*, either:
 - the cost of replacing, repairing, or reinstating the *contents* to a condition no better than they were when new, up to the *market value*. We'll subtract an amount for depreciation, and wear and tear
 - the reduction in value because of the *loss*, up to the *market value*.

Loss

Accidental physical loss or physical damage. It doesn't mean prevention of use or loss of functionality or usefulness.

Market value

The value of the *contents* immediately before the *loss*.

Natural disaster

An earthquake, natural landslip, volcanic eruption, tsunami, or hydrothermal activity – or fire resulting from any of these. It does not include a gradual or slow-moving natural landslip.

Period of insurance

The timeframe we provide your insurance cover for (usually 12 months), as shown on your *schedule*.

Premium

Any amounts you need to pay us to ensure cover commences and remains in force. This is the initial premium or any subsequent premium, and includes any government levies and taxes.

Reparation

An amount a New Zealand court orders you to pay to the victim of an offence under section 32 of the Sentencing Amendment Act 2014.

Reparation does not include:

- reparation arising from an offence under the Health and Safety at Work Act 2015
- *damages*, court costs, fines, any other kind of penalty (financial or not), taxes, and any payment that is unlawful to insure against
- your legal defence costs or expenses relating to an offence.

Replacement value

The cost of replacing, repairing, or reinstating *contents*, without deducting for wear and tear or depreciation.

Residential boundaries

The part of the land the *home* dwelling sits on, which you, members of your family, or your *tenants* mainly use for *residential purposes*.

Residential boundaries doesn't include any part of the land:

- which is used for commercial or farming purposes
- that's more than 150 metres away from a dwelling or garage used for *residential purposes*, if the *home* is on a property larger than 10,000 square metres and isn't serviced by a dedicated town mains water supply.

Residential purposes

The ordinary domestic activities of life — this doesn't include activities that have a business or commercial purpose.

Room

Any room(s), common area(s), and passageway(s) openly connected and not separated by any doors, doorways, or stairs.

Schedule

The policy schedule, policy change, endorsement, expiry notice, or renewal notice that we most recently issued to you or your insurance adviser.

Similar items

Items of *contents* with a similar nature, use, colour, texture, material, or design and includes items which form part of a set.

Sum insured

The amount your *schedule* shows your *contents* are insured for.

Tenant, tenants

The person (or people) who sign a tenancy agreement with you, including their spouse or partner and their family.

In this definition, a tenancy agreement is a written contract lasting for at least 90 days, giving the tenants the right to occupy your *home* in exchange for regularly paying rent.

Uninhabitable

We, or government or local authorities, determine the *home* is no longer a safe or sanitary place to live because of physical damage to the *home* — and we or they have therefore given you notice of this.

Uninhabitable doesn't mean you or your *tenants* not wanting to live in an otherwise safe or sanitary *home*.

Unoccupied

No authorised person has slept overnight in the *home* within the last 60 days.

0800 50 20 20

Mike Pero
Mortgages • Insurance • Finance

AON

vero